

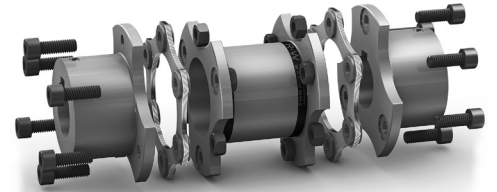

INSTALLATION AND OPERATING INSTRUCTIONS FOR R+W DISC PACK COUPLINGS: SERIES LP



GENERAL INFORMATION

The installation and operating instructions are important to successful use of R+W disc pack couplings. This document includes critical information regarding proper installation, operation, and maintenance. Please thoroughly read this document. Installation should only be performed by qualified personnel. Disc pack couplings should only be operated within the technical specifications. Additional information can be found in the product catalog LP.

 **This installation and operating instruction manual is not valid for ATEX requirements.**

SAFETY ALERT

Rotating couplings can be very dangerous. Proper guarding should be in place at all times and is the responsibility of the machine builder, user, or operator. Do not approach or touch a

coupling while it is rotating. Make sure the machine is "locked out" and cannot be accidentally started during installation or maintenance of the coupling.



Please pay attention to important notes / Safety warning

MANUFACTURER'S DECLARATION

According to EG guidelines for machinery 2006/42/EG, Appendix IIB.

As per machinery guidelines (MR), shaft couplings are not considered machines, but rather components for installation in a machine. Their putting into operation is subject to the fulfillment of all requirements of machinery regulations by or after integration into the final product.

MODELS WITH PARTS LIST

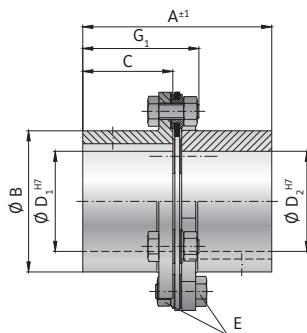

MODEL LP1/S

- | | |
|-------------------------|--------------|
| 2x Hub with keyway | 6x Bushing |
| 6x Screw (ISO 4017) | 6x Ring |
| 6x Nut (ISO 4032) | 1x Disc pack |
| 2x Set screw (ISO 4029) | |

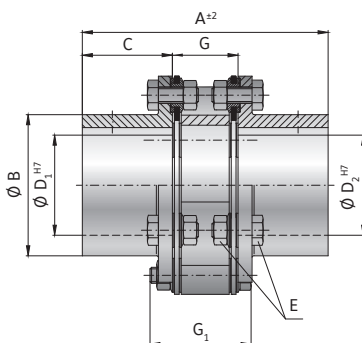

MODEL LP1/D

- | | |
|---------------------|-------------------------|
| 2x Hub with keyway | 2x Set screw (DIN 4029) |
| 1x Connection plate | 12x Bushing |
| 6x Screw (ISO 4017) | 12x Ring |
| 3x Screw (ISO 4017) | 2x Disc pack |
| 9x Nut (ISO 4032) | |

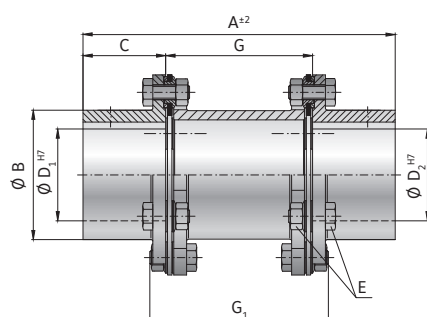

MODEL LP2

- | | |
|------------------------|-------------------------|
| 2x Hub with keyway | 2x Set screw (DIN 4029) |
| 1x Intermediate spacer | 12x Bushing |
| 12x Screw (ISO 4017) | 12x Ring |
| 12x Nut (ISO 4032) | 2x Disc pack |

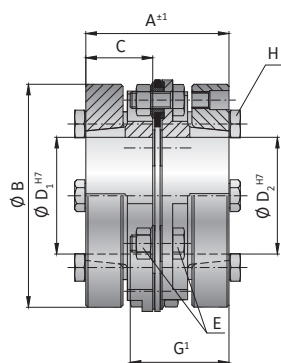

MODEL LP4/S

- | | |
|-------------------------|----------------------|
| 2x Conical clamping hub | 12x Screw (ISO 4017) |
| 2x Clamping ring | 6x Bushing |
| 6x Screw (ISO 4017) | 6x Ring |
| 6x Nut (ISO 4032) | 1x Disc pack |

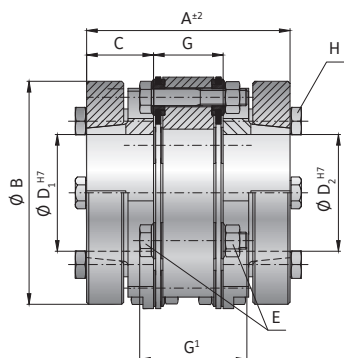

MODEL LP4/D

- | | |
|-------------------------|----------------------|
| 2x Conical clamping hub | 9x Nut (ISO 4032) |
| 2x Clamping ring | 12x Screw (ISO 4017) |
| 1x Connection plate | 12x Bushing |
| 6x Screw (ISO 4017) | 12x Ring |
| 3x Screw (ISO 4017) | 2x Disc pack |

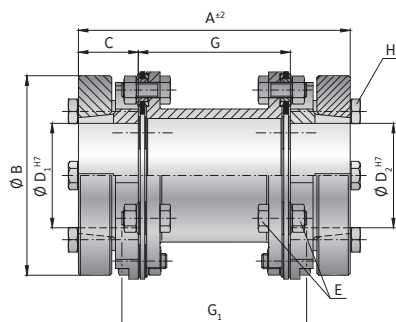

MODEL LP3

- | | |
|-------------------------|----------------------|
| 2x Conical clamping hub | 12x Screw (ISO 4017) |
| 2x Clamping ring | 12x Bushing |
| 1x Intermediate spacer | 12x Ring |
| 12x Screw (ISO 4017) | 2x Disc pack |
| 12x Nut (ISO 4032) | |

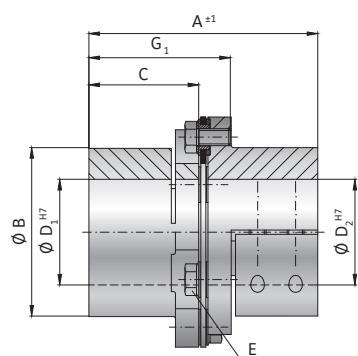

MODEL LP5/S

- | | |
|---------------------|--------------|
| 2x Clamping hub | 6x Bushing |
| 6x Screw (ISO 4017) | 6x Ring |
| 4x Screw (ISO 4762) | 1x Disc pack |

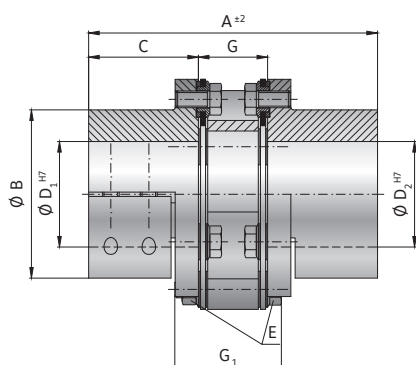

MODEL LP5/D

- | | |
|---------------------|---------------------|
| 2x Clamping hub | 4x Screw (ISO 4762) |
| 1x Connection plate | 12x Bushing |
| 6x Screw (ISO 4017) | 12x Ring |
| 3x Screw (ISO 4017) | 2x Disc pack |
| 3x Nut (ISO 4032) | |

MODELS WITH PARTS LIST

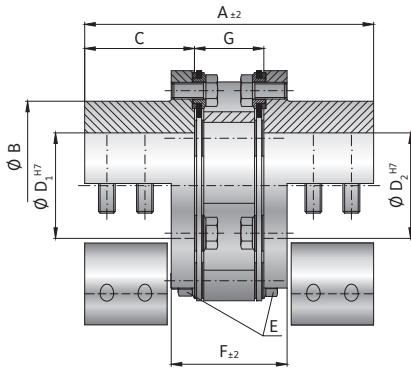

MODEL LPH/D

2x Split clamping hub	8x Screw (ISO 4762)
1x Connection plate	12x Bushing
6x Screw (ISO 4017)	12x Ring
3x Screw (ISO 4017)	2x Disc pack
3x Nut (ISO 4032)	

FUNCTION

R+W disc pack couplings are supplied pre-assembled. On request the couplings can also be delivered unassembled. Their purpose is to compensate for shaft misalignment (axial / lateral / angular) while transmitting rotary power. R+W disc pack couplings transmit torque across the disc pack assemblies purely by friction, thus

avoiding stress concentration, backlash, and micro-movements resulting from transmitting torque across the bolts (Grade 12.9). This aids in making the complete coupling assembly more torsionally stiff.

MOUNTING PREPARATION

The disc packs must not be flexed beyond their catalog rated misalignment values prior to or during installation or removal. Avoid any excessive force while mounting the coupling. All mounting surfaces including shafts, keys, bores, and keyways must be clean and free of burrs, nicks and dents. Inspect shaft diameters, coupling bore diameters, key, and keyway dimensions and tolerances. R+W disc pack coupling bores are machined to ISO tolerance H7. Clearances between shaft and

hub should be 0.01 - 0.05 mm. A light coating of machine oil is recommended to ease the mounting process and will not affect the clamping force of the hub.



Caution!

Do not use sliding grease or other oils and greases with molybdenum disulfide or other high pressure additives.

MAX. TRANSMITTABLE TORQUE/MISALIGNMENT VALUES

MODELS LP2 / LP3

SIZE			300	500	700	1100	1600	2600	4000	6000	8000	15000
Rated torque	(Nm)	T_{KN}	350	500	700	1,100	1,600	2,600	4,000	6,000	8,000	15,000
Max. torque	(Nm)	T_{KN}	700	1,000	1,400	2,200	3,200	5,200	8,000	12,000	16,000	30,000
axial ±	(mm)		1	1	1.5	1.5	2	2	2.5	2.5	2.5	3
lateral ±	(mm)		0.2	0.2	0.3	0.3	0.4	0.4	0.5	0.5	0.6	0.7
angular ±	(°)		1.4	1.4	1.4	1.4	1.4	1.4	1.4	1.4	1.4	1.4
Speed	(1/min.)		5,800	5,300	4,500	4,300	3,800	3,400	2,900	2,700	2,400	1,900



Caution! The maximum torque value must not be exceeded. The maximum misalignment of the disc pack coupling must not exceed a total of 100%.

MAX. TRANSMITTABLE TORQUE/MISALIGNMENT VALUES

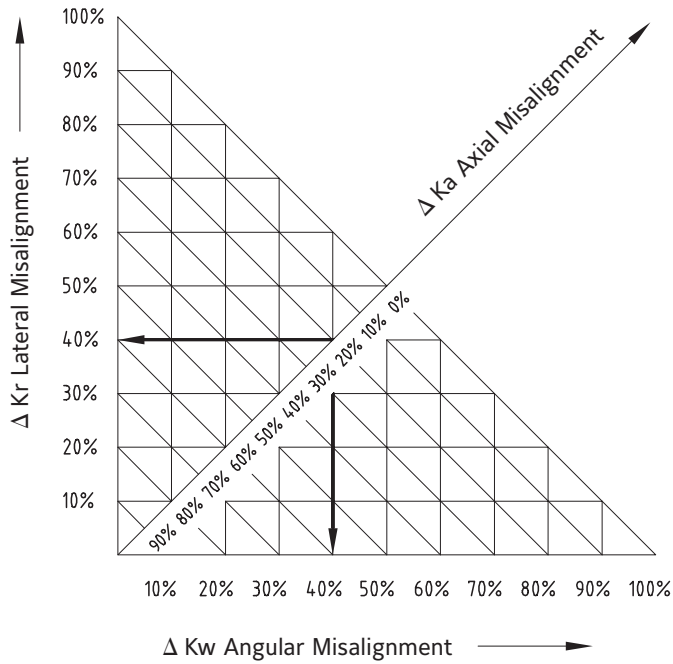

Prior to installation, the shaft misalignment must be measured. Each type of misalignment (axial / lateral / angular) must be calculated and checked against this chart.

Example LP 700:

Axial misalignment: 0.30mm -> 20%
 Lateral misalignment: 0.40 mm -> 40%
 Angular misalignment: 0.40° -> 40%

Total misalignment = 20% + 40% + 40% = 100%

Result: The calculated present misalignment values can be compensated for by the coupling. The LP disc pack coupling can be installed.

$$\Delta K_{total} = \Delta K_r + \Delta K_w + \Delta K_a \leq 100\%$$

ASSEMBLY OF THE DISC PACK

If the R+W disc pack coupling is delivered unassembled, the following steps must be taken to ensure proper assembly. Delivery consists of 2 drive hubs, 1 or 2 disc pack sets, 6 or

12 assembly screws and nuts, and possibly an intermediate spacer.

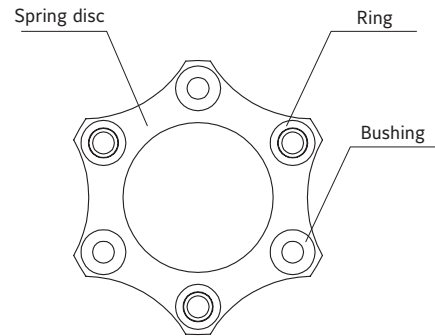
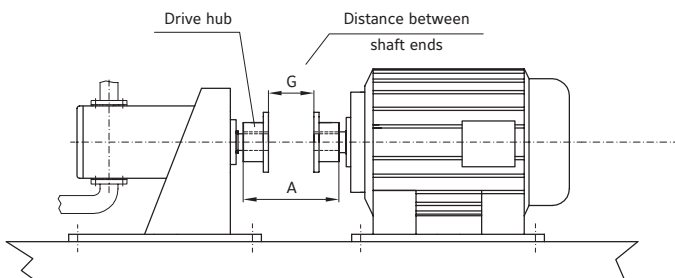

- 1 The connecting shafts and bores must be clean and free of nicks, burrs and dents. Clean the contact surfaces of the drive hubs, disc pack sets, assembly screws and nuts.
- 2 Slide the drive hubs onto their respective shafts. For easier installation, the drive hubs can be heated to 80 C.
- 3 Insert the disc packs, including any spacers, as well as the bolt and nuts, and tighten until the disc pack bushings are seated in their pockets.

- 4 In a circular pattern (not crosswise) apply the bolt tightening torque in steps (30% / 60% / 100%).
- 5 Tighten the drive hub screws.

MODEL LP1 / LP2 / LP3 / LP4 / LP5 / LPH

SIZE		300	500	700	1100	1600	2600	4000	6000	8000	15000
LP1 / LP2 Screw + nut (ISO 4017 + ISO 4032)	A	M8	M8	M10	M10	M12	M12	M16	M16	M20	M20
Tightening torque ¹⁾	(Nm)	35	40	65	95	150	165	360	400	755	670
LP4 / LP3 Screw + nut (ISO 4017 + ISO 4032)	A	M8	M8	M10	M10	M12	M12	M16	M16	M20	M20
Tightening torque ¹⁾	(Nm)	35	40	65	95	150	165	360	400	755	670
LP4 / LP3 Screw (ISO 4017)	B	M8	M8	M10	M10	M12	M12	M16	M16	M20	M20
Tightening torque ¹⁾	(Nm)	20	26	39	61	98	140	255	308	490	620
LP5 Screw (ISO 4017)	A	M8	M8	M10	M10	M12	M12	M16	M16	M20	M20
Tightening torque ¹⁾	(Nm)	35	40	65	95	150	165	360	400	755	670
LP5 Screw (ISO 4762)	C	M6	M8	M8	M10	M10	M12	M14	M16	M20	M18
Tightening torque ¹⁾	(Nm)	18	34	39	73	120	192	246	395	615	500
LPH Screw (ISO 4017)	A	M8	M8	M10	M10	M12	M12	M16	M16	M20	M20
Tightening torque ¹⁾	(Nm)	35	40	65	95	150	165	360	400	755	670
LPH Screw (ISO 4762)	C	M6	M8	M8	M10	M10	M12	M14	M16	M20	M18
Tightening torque ¹⁾	(Nm)	18	34	39	73	120	192	246	395	615	500

¹⁾ If MoS₂-grease is used on the screw head contact surface and the thread, the tightening torque can be reduced by 40%.

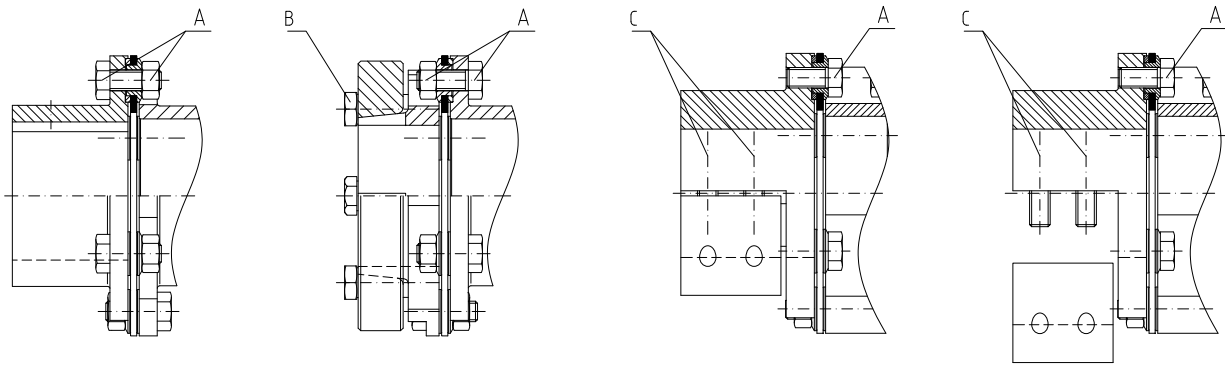

MAINTENANCE

The following inspection intervals are recommended for R+W disc pack couplings:

- 1 Prior to commissioning: Check the assembly parameters (misalignment and tightening torques), and perform a visual inspection of the coupling to check for any abnormalities or deformation.
- 2 Every 1100 hours or 3 months: Perform a visual inspection, check misalignment and tightening torques. Check for backlash or any kind of deformation.
- 3 If after the second inspection interval no irregularities or wear are discovered, the inspection interval can be extended to 4100 hours or 12 months.



R+W Antriebselemente GmbH
 Hattsteinstraße 4 · D-63939 Wörth am Main
 Phone +49 9372 9864-0 · Fax +49 9372 9864-20
 info@rw-kupplungen.de · www.rw-couplings.com

The above-mentioned information is based on our present knowledge and experiences and does not free the user of his or her obligation to perform regular inspection. A legally binding guarantee is not granted even in regard to protection rights of third parties.